

Description

The CXP84200 is a CMOS 8-bit single chip micro-computer of piggyback/evaluator combined type, which is developed for evaluating the function of the CXP84220/84224.

Features

- Wide-range instruction system (213 instructions) to cover various types of data
 - 16-bit operation/multiplication and division/Boolean bit operation instructions
- Minimum instruction cycle 400ns at 10MHz operation
- Applicable EPROM LCC type 27C128, LCC type 27C256
(Maximum 24K bytes are available.)
- Incorporated RAM capacity 624 bytes
- Peripheral functions
 - A/D converter 8-bit, 8-channel, successive approximation method
(Conversion time of 32 μ s/10MHz)
 - Serial interface Incorporated 8-bit, 8-stage FIFO
(Auto transfer for 1 to 8 bytes), 1 channel
8-bit clock sync type, 1 channel
 - Timer 8-bit timer
8-bit timer/counter
19-bit time base timer
16-bit capture timer/counter
 - Remote control reception circuit 8-bit pulse measurement counter with on-chip 6-stage FIFO
 - PWM output 14 bits, 1 channel
- Interruption 14 factors, 14 vectors, multi-interruption possible
- Standby mode Sleep/stop
- Package 64-pin ceramic SDIP

Note) Mask option depends on the type of the CXP84200. Refer to the Products List for details.

Structure

Silicon gate CMOS IC

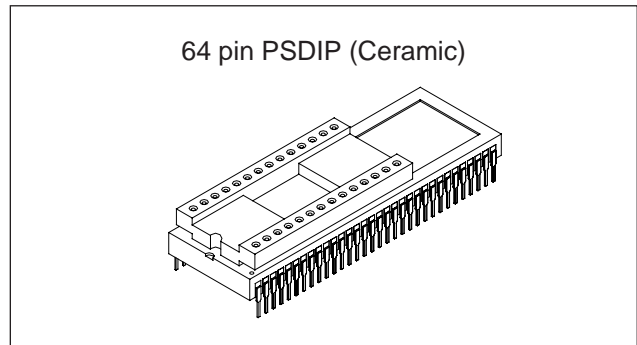

64 pin PSDIP (Ceramic)

Sony reserves the right to change products and specifications without prior notice. This information does not convey any license by any implication or otherwise under any patents or other right. Application circuits shown, if any, are typical examples illustrating the operation of the devices. Sony cannot assume responsibility for any problems arising out of the use of these circuits.

Pin Assignment in Piggyback Mode

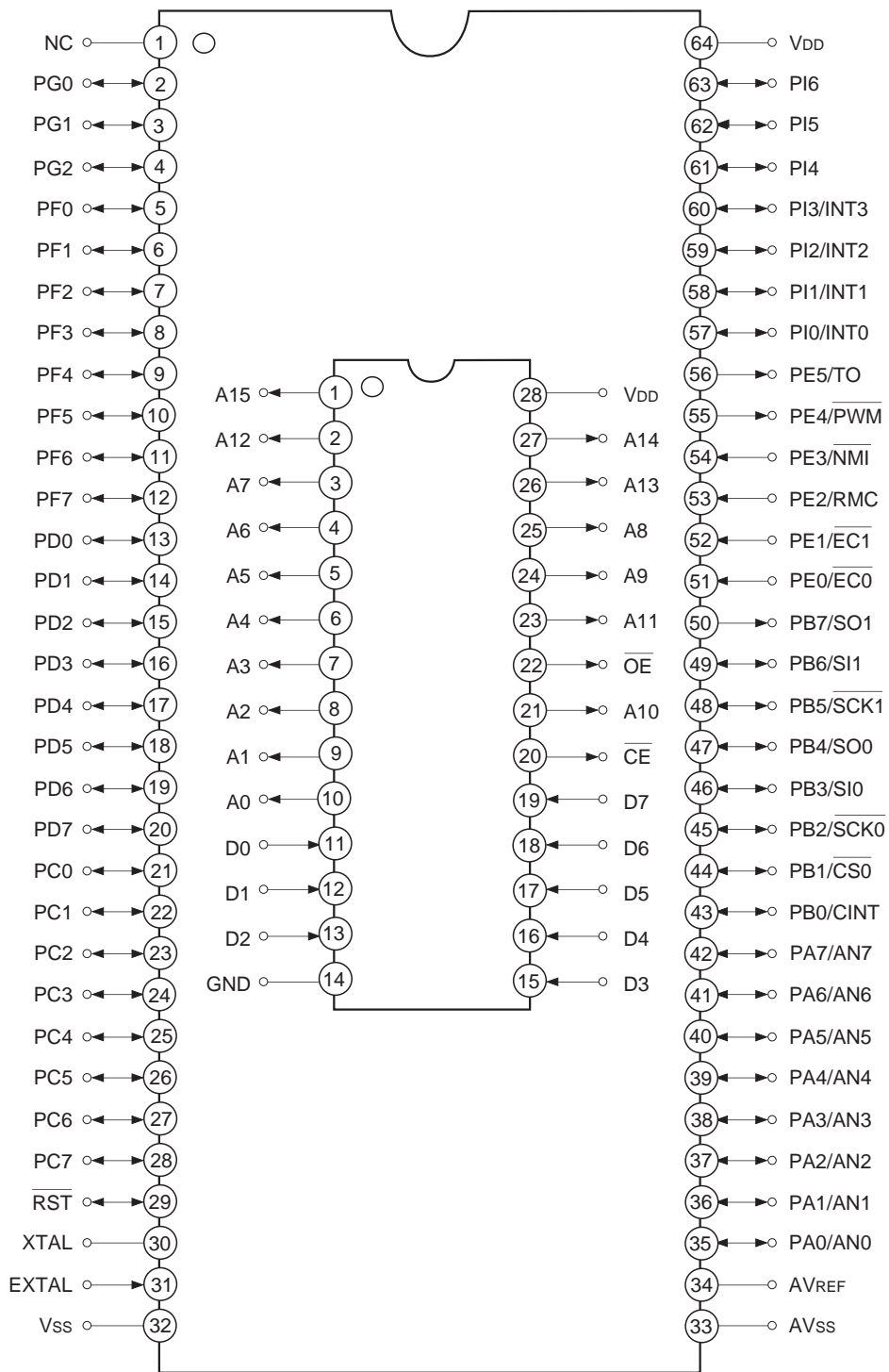

Note) NC (Pin 1) is always connected to VDD.

Pin Assignment in Evaluator Mode

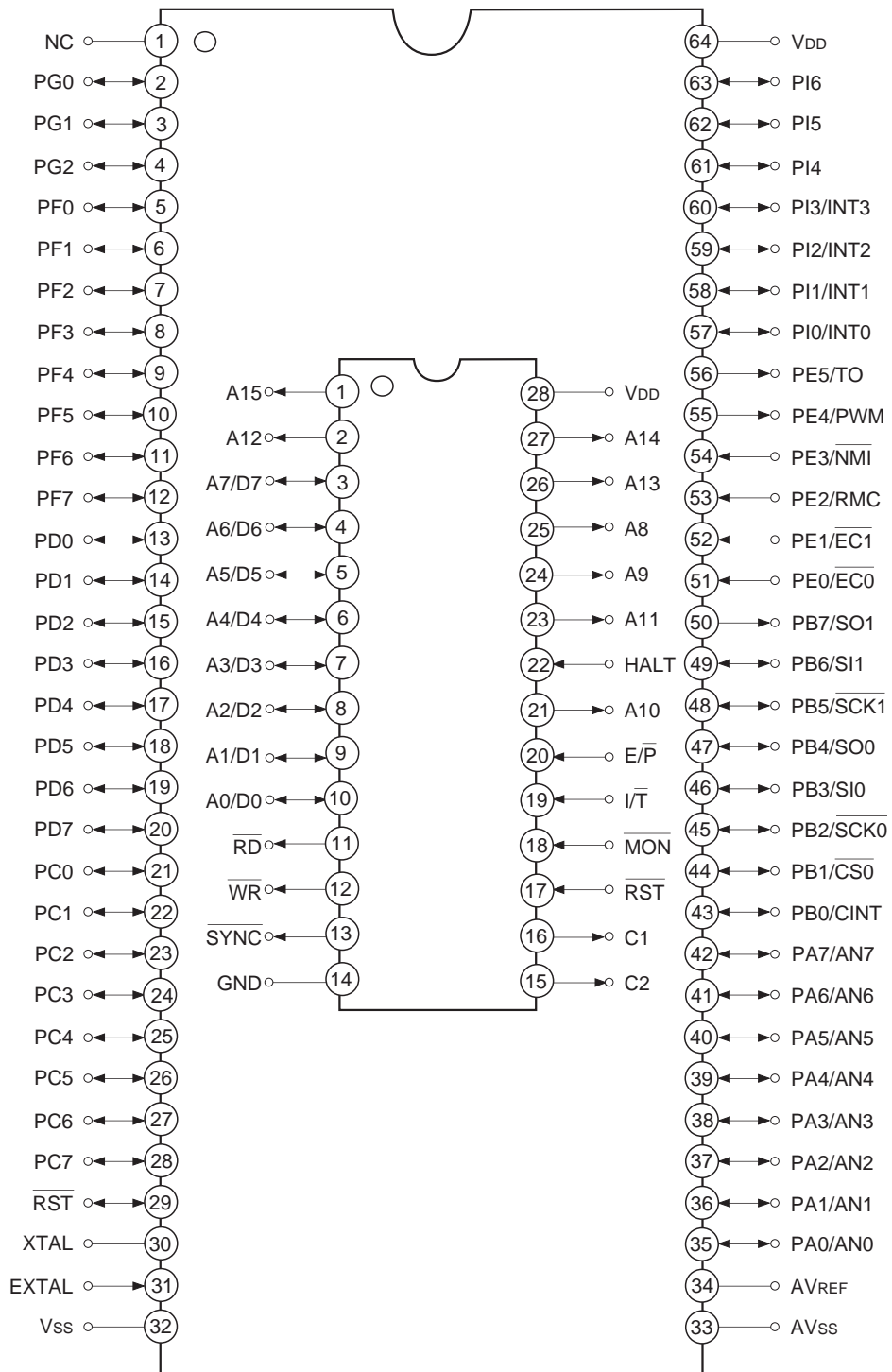

Note) NC (Pin 1) is always connected to VDD.

EPROM Read Timing

($T_a = -20$ to $+75^\circ\text{C}$, $V_{cc} = 4.5$ to 5.5V , $V_{ss} = 0\text{V}$ reference)

Item	Symbol	Pins	Min.	Max.	Unit
Address → Data Input delay time	t_{ACC}	A0 to A15 D0 to D7		120	ns
Address → Data Hold time	t_{IH}	A0 to A15 D0 to D7	0		ns

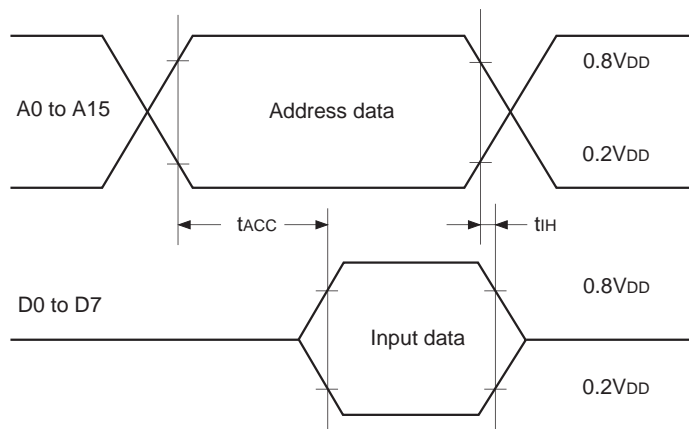

Products List

Option item	Products		
	Mask		Piggyback/evaluator
	CXP84220	CXP84224	CXP84200-U01S
Package	64-pin plastic SDIP		64-pin ceramic PSDIP
ROM capacitance	20K bytes	24K bytes	24K bytes
Pull-up resistance for reset pin	Existent/Non-existent		Existent
Power-on reset circuit	Existent/Non-existent		Existent

Piggyback mode/evaluator mode can be switched as shown below.

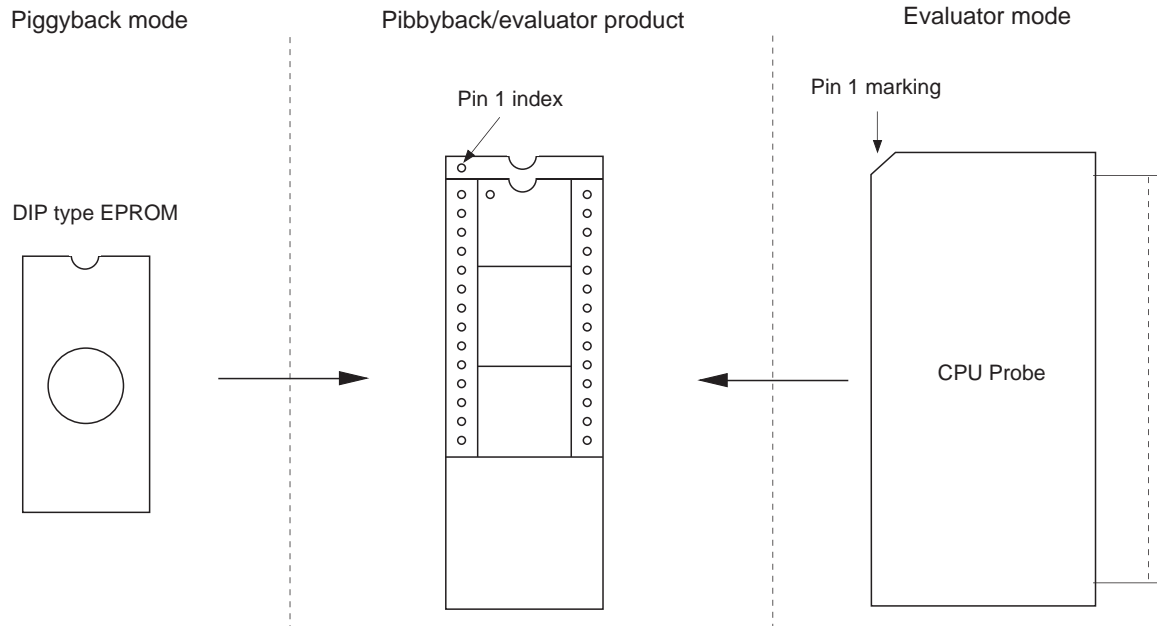

Package Outline

Unit: mm

64PIN PSDIP (CERAMIC) 750mil

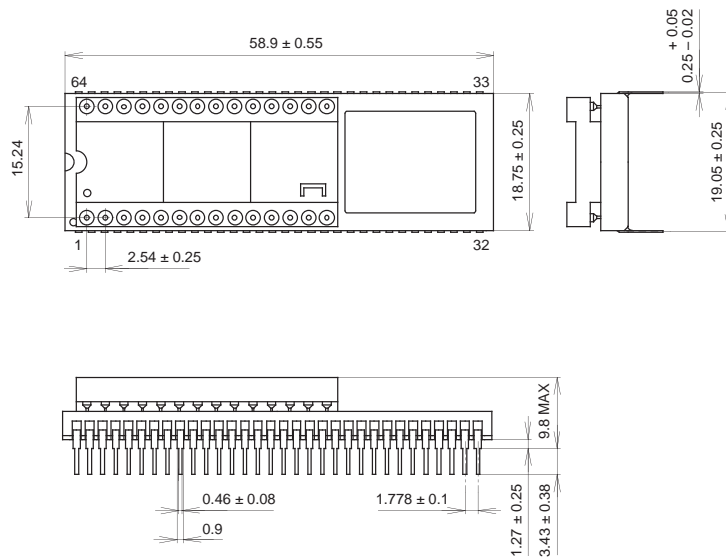

PACKAGE STRUCTURE

SONY CODE	PSDIP-64C-01	PACKAGE MATERIAL	CERAMIC
EIAJ CODE	ADIP064-C-0750-A	LEAD TREATMENT	GOLD PLATING
JEDEC CODE	_____	LEAD MATERIAL	42 ALLOY
		PACKAGE WEIGHT	16.0g